

# Parametric Mechatronic Design – A driver for modern optimised systems and plants

**Stefan DIERNEDER**  
Linz Center of Mechatronics GmbH,  
4040 Linz, Altenbergerstrasse 69, Austria

## ABSTRACT

Modern large and complex industrial production systems, for instance for steel, paper or plastics, have to be optimized for each customer by tailor made systems. The enormous throughput and resource consumption on the one hand and the relatively low profit margin on the other hand make tailor-made systems the preferred solution over standard systems.

Such production systems have nowadays an expressed mechatronic nature, since the performance needed today in terms of throughput, quality, productivity, safety, to name just a few, cannot be met without advanced control, precise and fast response drives and actuators, up to date human machine interfaces, sensors systems for various states, automatic fault detection systems and powerful communication devices.

The engineering processes for the customer specific tailoring are a complex and challenging work. Even worse, the available time for such projects is shrinking and the average failure rate has to be kept low.

Obviously, methods and tools to support the engineering work are needed to cope with these challenges. In this paper, parametric design as one of such methods will be discussed.

**Keywords:** Design Optimisation, Parametric Design, Mathematical Modelling

## 1. INTRODUCTION

Parametric design as a term was brought up by modern CAD systems. There, it is primarily understood as a technique to modify a certain geometric design by changing some of its parameter values (design parameters). Such features are offered by most of the powerful CAD packages today. From an engineering point of view, modifying only the geometric properties is

insufficient but has to be guided by appropriate rules, process and design modelling and simulation. Such rules reflect the relations between functional requirements, relevant physical laws, manufacturing constraints, standardisation issues, material properties and geometry or its design parameters, respectively.

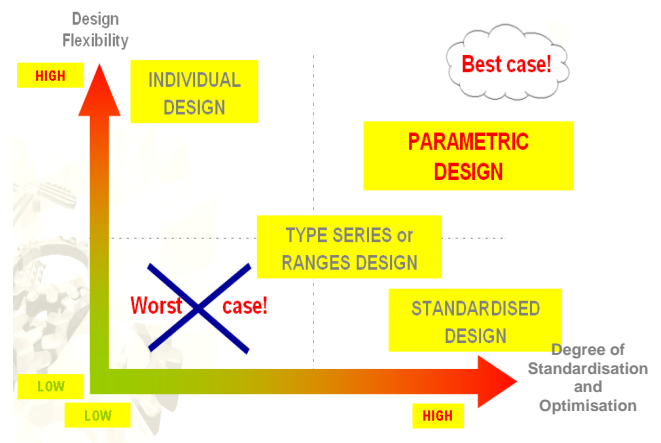

**Figure 1:** Common design methods from the perspectives standardization, optimization and flexibility

Figure 1 shows the most common design methods under the perspectives standardisation, optimisation potentials and design flexibility. Following this figure, parametric design represents a useful compromise.

## 2. PARAMETRIC DESIGN

At first glance, 3D parametric design is a term related to modern CAD systems that means parametric geometry design and seems only important for the description of the mechanical parts or sub-systems of a mechatronic product – which following a definition by J. Buur [1] is characterized by the tight integration and functional interaction of mechanical, electrical and software

components – or for geometry definition of other components, like electrical or micro-mechanical ones. The original intentions for the introduction of parametric design have been the simple realisation of a variant design and the fast and easy modifications of the design. From a more abstract point of view parametric design is more general than variant generation and easy modification. In all mechanically dominated systems it is closely related to geometry design. Design parameters also can be variable process parameters to study the behaviour and functionality of the design within its full operating range.

Figure 2 shows the different design levels – reaching from ordinary 2D and 3D design up to powerful 3D parametric design models. There is an optimisation potential by the integration of several design rules, as well as by the extended use of analytic and / or numerical simulations, parameter studies and by complexity analysis covering the overall mechatronic product design process.

### Parametric Design – Modelling Depth

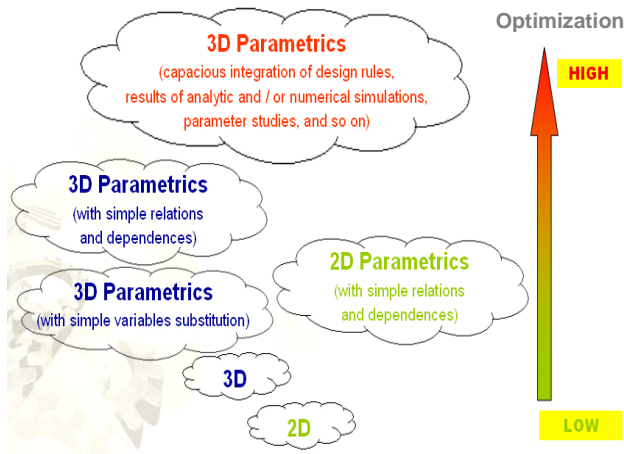

**Figure 2:** Optimization potentials of different levels of parametric design

A nontrivial question is in which software the design rules of a parametric design for a certain machine or machine component should be implemented. Nowadays, this could be done within the CAD system itself but also outside for instance with standard spreadsheet programs – for an example see Figure 3 – or an individual hierarchical data structure – similar to object oriented programming in software engineering – with an abstract CAD interface using, e. g., the so-called applications programming interfaces of the individual CAD systems.

Depending on the geometric and functional complexity of the considered system and the advanced physics involved, clear arguments for choosing the appropriate method for parameter handling. Besides this, a clear assignment of rights for the set-up and modification of all the models to

responsible persons is important for the success of parametric design for and for an optimal engineering.

This automatically

- assists the standardisation efforts which are economically very important
- documents the design in a more universal and better useable manner
- documents the responsibilities of persons

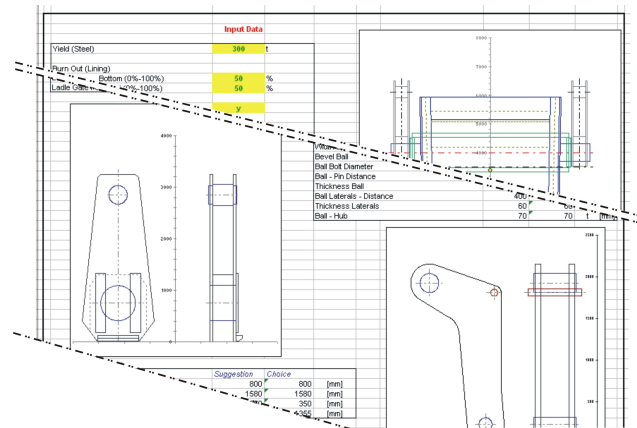

**Figure 3:** Example of a standard spreadsheet parameter file

In metallurgical machinery parametric design solutions that automatically define 100 % of a machine are neither economical nor practicable. Room must be left for case specific adaptations which according to the experience gained by the authors in several industrial projects cover approximately 20 % of the whole design. With reduced percentage – approx. 5 to 15% – this also applies for the design of almost all modern mechatronic systems.

Experiences with this parametric design approach that have been gathered in the last 10 years show several decisive economical benefits: Machine complexity, error rates, basic and detail design costs, and the project execution time could be reduced. The awareness of the design team for a systematic approach, for clear responsibilities, and for the high importance of a thorough conceptual design increased.

### 3. DESIGN OPTIMIZATION BASED ON THE DESIGN PARAMETERS

The system-relevant models of the considered systems are the essence of a successful parametric design. These models, preferably of mathematical behaviour such as shown in Figure 4, should represent the relationship between the relevant physics behind the system – such as physical balance or material laws, the given so-called

functional requirements (FRs) and the considered design parameters (DPs).

$$\phi_3(t) = \frac{b m g}{\gamma_3} + \frac{b^3 k_{friction}^2 h}{r_3^2 [m^2 \Omega^2 (r_3^2 - 2 a b) - 2 m \gamma_3] + \left( \Omega m b a + \frac{\gamma_3}{\Omega} \right)^2 + b^4 k_{friction}^2} \sin(\Omega t) + \frac{b h k_{friction} \left[ m \Omega (a b - r_3^2) + \frac{\gamma_3}{\Omega} \right]}{r_3^2 [m^2 \Omega^2 (r_3^2 - 2 a b) - 2 m \gamma_3] + \left( \Omega m b a + \frac{\gamma_3}{\Omega} \right)^2 + b^4 k_{friction}^2} \cos(\Omega t)$$

Figure 4: Extract from the mathematical model of a linear oscillatory drive [2]

Figure 5 shows such design relations by a dependency graph (DG). As indicated in the graph, the state X (or functionals of it) of the system and the FRs and DPs are involved. Clearly, the state X can be a more complex quantity than a vector, for instance an element of a function space if field problems are involved. Following Nam P. Suh’s first of his two design axioms [3, page 47], the so-called “Independence Axiom”, claims that a good solution concept is characterised by an uncoupled relation between the FRs and the DPs, what also simplifies the optimisation process. Additionally, the concept of parametric design can be applied with and will be forced by the functional based design methods called “Functional Decomposition Method”, see [2], respectively “Functional Analysis”, [3].

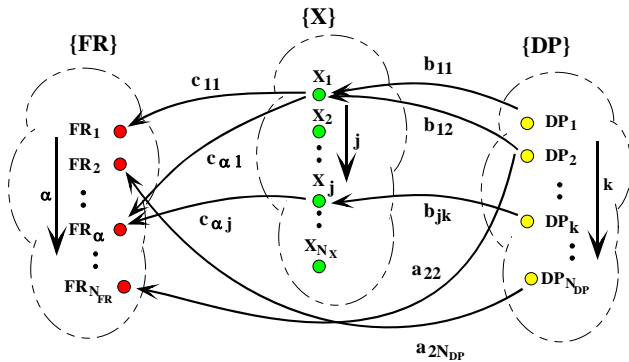

Figure 5: Dependency Graph – showing the relations between the FRs and DPs, see [4]

### How can the Design Parameters be classified?

The design parameters can be of geometric nature as well as several process or structural parameters or even denominated toggle parameters for CAD model control.

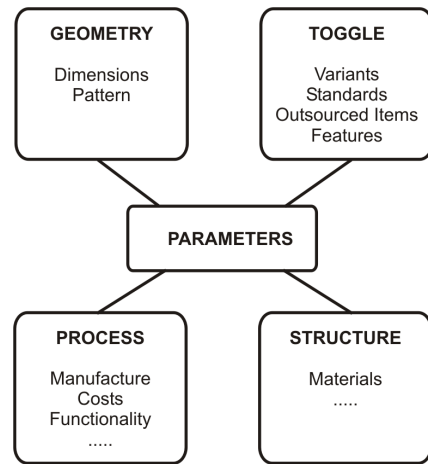

Figure 6: Design parameter classification, [6]

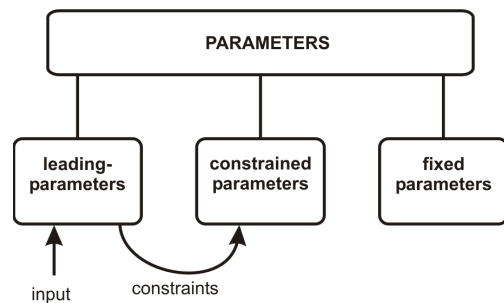

Figure 7: Design parameter classification, [6]

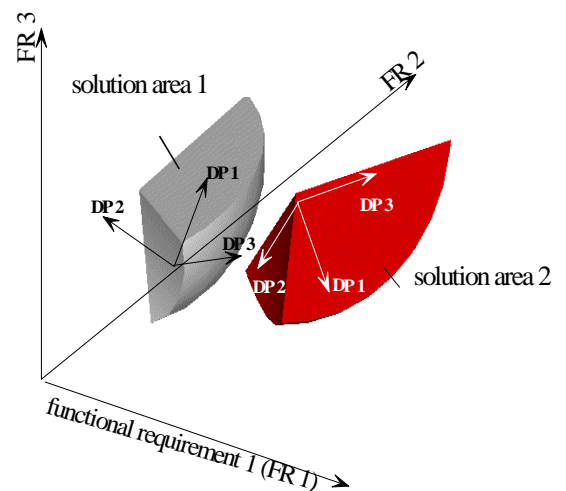

Figure 8: Design Solution Areas spanned by the design parameters in the global space of the functional requirements, based on [7]

Based on their determination the parameters can also be classified into so-called lead-parameters, dependent- or constrained- and fixed-Parameters. A typical ratio of dependent- to lead-parameters is 15/1 and more. The associated dependences and relations can be of explicit or implicit nature. Another distinction concerns the parameters' validity range, leading to the two classes global design parameters (valid for more than one part e. g. in an assembly) and local design parameters (only valid for one specific part).

### Which parameters are relevant for design optimisation?

For design optimization only the leading parameters are relevant. Each output of such an optimization process can be seen as a member of a family of variants spanned by all admissible leading parameter combinations which assure the required performance (see [6] and [7]).

## 4. EXAMPLES

The following examples demonstrate the power of parametric design, both for small devices and for heavy machinery.

### Example 1 – Optimised design of a mechanical oscillator as a sensor component

A magnetically excited mechanical oscillator, being part of a thermal radiation scanner, has to be tuned for a certain resonance frequency. Its geometry and dimensions are varied. Without parametric design this needed many iterations. With 3D parametric design the sensors' design could be held flexible by setting up mathematical models and dependencies based on the required sensor characteristics like its natural oscillation frequency. Frequency tuning can be done in a straight-forward manner using the derived rules for the resonance frequency. Figure 9 shows the influence and optimisation potential of the design-parameter “additional mass” as one possible tuning parameter for the final sensor frequency.

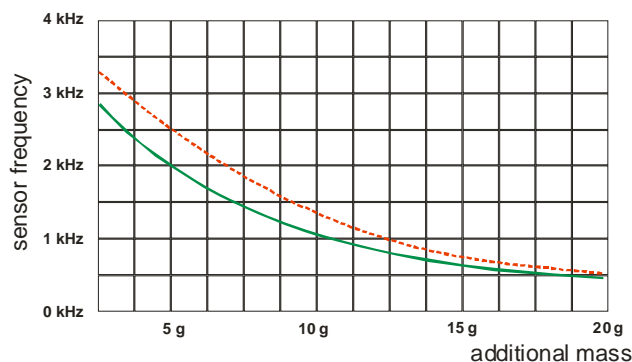

Figure 9: Frequency influence of the design-parameter “additional mass”

### Example 2 – Optimised geometry by well defined parametric design

The same optimisation and quality enhancement aspect has been demonstrated for the chamfer design of a shaft of a rolling mills work roll, [8]. The main goal there was to create a design rule for assuring a minimal stress concentration factor for each design variant of the work rolls. Based on analytical design studies and some numerical Finite Element analyses of different designs with different extensions, an analytical relationship between the given constraints, process parameters and the stress concentration factor has been worked out and set up – see Figure 10. Hereby, a standard has been created with enough flexibility to realise different work roll variants, each of them being optimised w.r.t. the stress concentration factor.

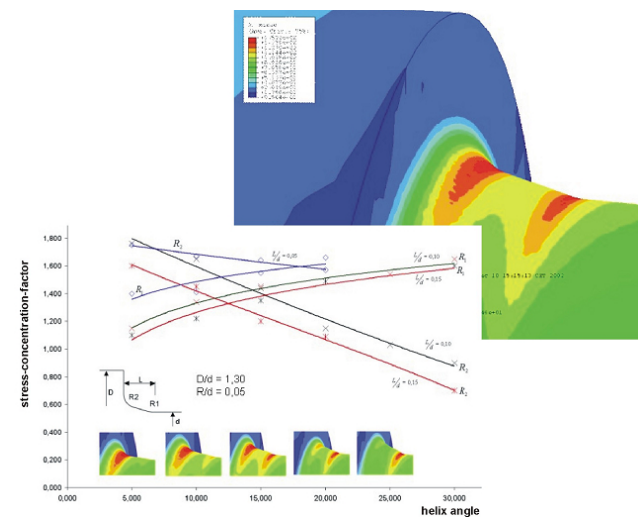

Figure 10: Example of a global chamfer shape (stress-concentration-factor for different parameter sets), [8]

### Example 3 – Load dependent optimised design of a crop shear

The main objective of this industrial project was an optimised design of a crop shear for cutting the front-end and the tail of a steel band at hot rolling. This included the simplification and the standardization of the design concept and the operation process.

The system has been designed as a so called “drum shear”, see Figure 11, where two rotating drums, every drum with one or two knives accelerates and cuts steel band exploiting its rotary inertia. The cut band dimensions vary between 20 to 60mm thickness and 1500 to 3500mm width. The according cutting force may go up to 25000kN, which constitutes a very high load on the drums.

The main problem of this high load are not the resulting stresses but the drum deflection and, according to this, the inclination within the drum bearings. The drum deflection has to be reduced but same time kept in an allowed design space.

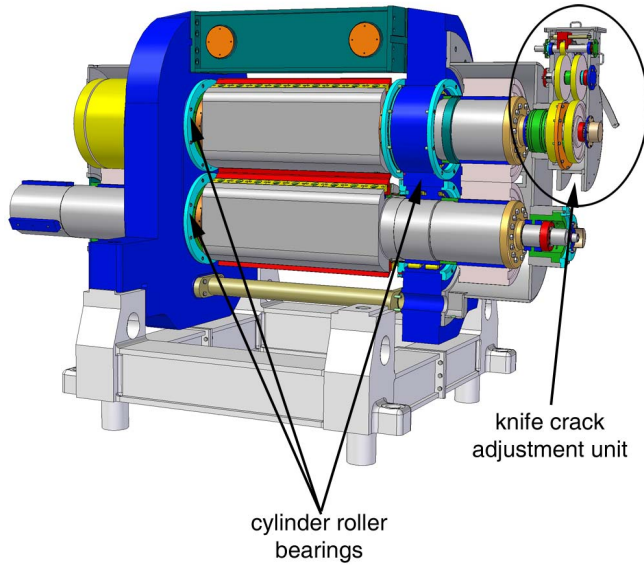

Figure 11: Crop shear and detail of the drum, [9]

The drums are supported by multi-row cylinder roller bearings, which are tolerating only a very low inclination of typically 3-5 angular minutes. Traditionally, the selection of bearings and drum-diameter is an iterative process of dimensioning and examination with complex FEA analysis. With the developed new parametric model the FEA is minimized to one final verification, and the whole dimensioning work can be performed in a very short time.

$$\frac{d^2}{dx^2} w(x) = \frac{1}{EI_Y} \cdot M_Y(x)$$

Figure 12: Differential equation of the drum bending model

Heart of the parametric model is the drum bending according to the differential equation shown in Figure 12. The centre and drum-angle of the rotation where the maximum force occurs is known by appropriate measurements. Additionally, the ratio between horizontal and vertical components of the cutting force was obtained experience. With the moment of inertia and the boundary conditions of the different drum sections the deflection angle can be derived and the shear can be optimized, finally as a function of the given (lead)-parameters - see Figure 13.

The resulting comprehensive drum dimensioning formulas have been implemented in a parameter file, see [9] for further details.

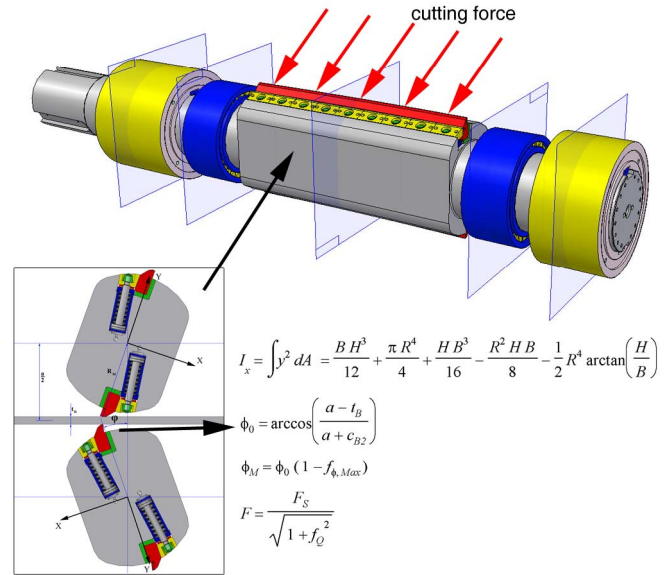

Figure 13: Deflection model, [9]

## 5. SUMMARY AND OUTLOOK

Summing up, parametric design is a method with a high optimisation potential concerning cost saving, quality improvement, and lead time reduction for advanced parts, components and systems ranging from small parts to large industrial plants.

The presented examples show the power and the optimisation potential of parametric design best.

Because of the corresponding modelling of the considered systems, parametric design additionally increases product transparency and, consequently, improves the reliability and quality of project execution. Parametric design also can be combined with other design methods, like type series, individual or standard design. The underlying design concept and embodiment design must be revised for an efficient parameterization. The optimisation primary will be performed by the lead parameters, which have to be suited best to adjust the concept to the given requirements.

The results achieved so far will be extended to further mechatronic components and large assemblies, which promise to be parameterized in an economic way. Further efforts will be devoted to an advanced, systematic and transparent linking of the data flow between the different design and development processes done at different departments as well as between the different design software tools.

## 6. REFERENCES

- [1] J. Buur, “**Does mechatronics need a special design attitude?**”, Proc. Mechatronics Research Conf., 13<sup>th</sup>-15th Sept. 1990, St. Albans, England, I MECH E
- [2] S. Dierneder, S. Dierneder, **The Functional Decomposition Method**, (original title: Die Methode der Funktionalen Zergliederung – Funktionale Zergliederung als Basis für eine weitgehend automatisierte Variantenkonstruktion von mechatronischen Systemen und Anlagen), PhD-thesis, University of Linz, Austria, 1999
- [3] N. Cross, Engineering Design Methods, 2<sup>nd</sup> edition, Wiley, Chichester, 1994
- [4] R. Scheidl, S. Dierneder, K. Mörwald, **Computer Aided Conceptual Design by a Functional Decomposition Method for Process Oriented Heavy Machinery and its Relation to Mechatronization**, Lancaster Int. Workshop on Engineering Design - Computer Aided Conceptual Design, Lancaster, UK, Proc. CACD’98, Eds.: A. Bradshaw, J. Counsell, Lancaster University, 1998
- [5] Nam P. Suh, **The Principles of Design**, Oxford University Press, New York, 1990
- [6] S. Dierneder, C. Rudig, **Modern Plant Design with extended 3D Parametrics**, The 16th International Design Seminar, Kananaskis, Alberta, Canada, Proc. CIRP’06, Calgary, Canada, 2006
- [7] S. Dierneder, R. Scheidl, **Conceptual Design, Functional Decomposition, Mathematical Modelling, and Perturbation Analysis**, Lecture Notes in Computer Science 1798, Computer Aided Systems Theory – EUROCAST’99, eds.: F. Pichler, R. Moreno-Díaz, P. Kopacek, A Selection of Papers from the 7th International Workshop on Computer Aided Systems Theory, Vienna, Austria, September/October 1999, Springer-Verlag Berlin-Heidelberg-New York, 1999
- [8] C. Rudig, **A 3D-CAD parametric model for work rolls of a hot rolling mill including stability proof**, (original title: Ein 3D-CAD Parametermodell für Arbeitswalzen eines Warmwalzwerkes inclusive Festigkeitsnachweis), Diploma-thesis, University of Linz, Austria, 2004
- [9] C. Rudig, G. Witwer, S. Dierneder, **Efficient and reconfigurable design with 3D parametrics**, Proc. ASME/IFToMM International Conference on Reconfigurable Mechanisms and Robots (ReMAR 09), 2009, London, UK

## 7. ACKNOWLEDGEMENT

The authors gratefully acknowledge the sponsoring of this work by the 'Austrian Center of Competence in Mechatronics' in the framework of the COMET program of the Austrian government. This program is funded by the Austrian government, the province Upper Austria and the scientific partners of the ACCM especially the Johannes Kepler University Linz.