

# A Linear Model of Magnetostrictive Actuators for Active Vibration Control

Francesco BRAGHIN, Simone CINQUEMANI, Ferruccio RESTA  
Mechanical Engineering Department, Politecnico di Milano,  
Campus Bovisa Sud, via La Masa 1, 20156, Milano, Italy

## ABSTRACT

If there is one actuator technology that is almost exclusively linked to a single application, that is the magnetostrictive actuator, the application is active structural vibration control (AVC). Almost all the applications described in the literature on magnetostrictive actuators are related in one way or another to vibration suppression mechanisms.

Magnetostrictive actuators (MA) deliver high-output forces and relatively high displacements (compared to other emerging actuator technologies) and can be driven at high frequencies. These characteristics make them suitable for a variety of vibration control applications.

The use of this technology, however, requires an accurate knowledge of the dynamics of such actuators. The paper introduces a linear model of magnetostrictive actuators hold in a range of frequencies below 2 kHz useful in real time application as AVC. The hypothesis supporting the linearity of the systems are discussed and the theoretical model is presented. Finally the model is validated by testing two different models of magnetostrictive actuators and comparing experimental results with the theoretical ones.

## 1. MAGNETOSTRICTIVE ACTUATORS

### The magnetostrictive effect

The term magnetostriction is a synonym for magnetically induced deformation and refers to the capacity, that most of ferromagnetic materials have, to change their size when the level of magnetization of the material itself changes. The magnetization variation is a result of a re-orientation of magnetic domains within the material. This change of direction can be obtained by subjecting the material to changes in magnetic field, stress or temperature.

Although most of ferromagnetic materials having magnetostrictive properties, only those that contain elements known as *rare earths* are able to develop these properties significantly. Such materials are called Giant Magnetostrictive Material. This effect is made possible by a high level of magnetomechanical coupling due to reorientation of the magnetic domains within the material itself.

When a magnetic field is applied to a magnetostrictive material, the magnetic domains rotate in the direction of the magnetic field producing a deformation in the material structure and a deformation of the material itself. The so-called positive magnetostriction produces an elongation and a pinch of the material, conversely, the negative magnetostriction is characterized by a shortening of the material and a corresponding increase in section (Fig.1).

The change in the state of magnetization can be reversible or irreversible. Reversible changes are energy conservative and are observable with small variations in the magnetic field.

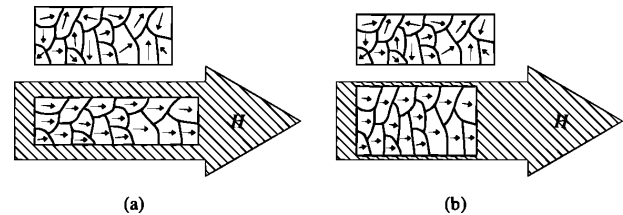

Figure 1: Positive (a) and negative (b) magnetostriction

Under these conditions, when the magnetic field returns to its initial value, the material returns to the original state of magnetization. Conversely, when applied magnetic fields are too high, changes in the state of magnetization are irreversible [1-2].

### Functioning principle

In practice the functioning of a M.A. can be described with reference to the scheme in Fig.2: a bar of magnetostrictive material is placed inside a coil and it is subjected to a magnetic field generated by permanent magnets positioned outside the coil itself. Feeding the solenoid, a variation of the electric field that passes through the magnetostrictive material produces a change in the opposite magnetic field with the subsequent alignment of magnetic domains. This phenomenon leads to a shift actuator and to the generation of a very high force.

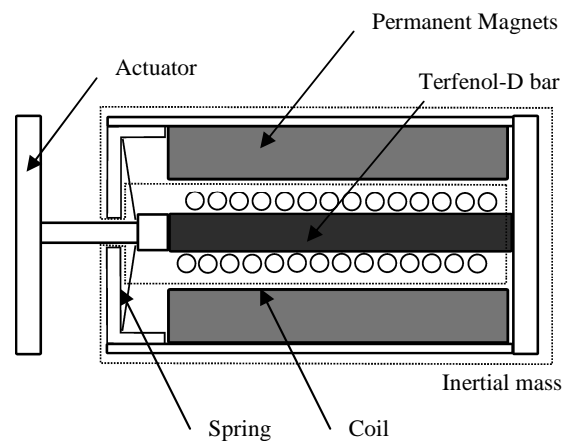

Figure 2: Layout of a M.A.

## 2. THE MODEL

The use of this technology, however, requires an accurate knowledge of the dynamics of such actuators.

The paper introduces a linear model of magnetostrictive actuators hold in a range of frequencies below 2 kHz useful in real time application as (AVC).

### Linear constitutive equations

The behaviour of magnetostrictive materials is complex but, under appropriate conditions, it can be approached as linear [10-14]. Main hypothesis consists in:

- low working frequencies,
- reversible processes of magnetostriction (no power losses),
- stress and strain uniform in all the sections of the magnetostrictive rod..

Under these conditions the coupling between the mechanical strain and the magnetization of the material is represented by the linear magnetomechanical coupling equations [10]:

$$S = s^H T + dH \quad (1)$$

$$B = dT + \mu^T H \quad (2)$$

with strain  $S$ , stress  $T$ , mechanical compliance  $s^H$  at constant applied magnetic-field strength  $H$ , linear piezomagnetic cross-coupling coefficients  $d$  and  $d^*$ , magnetic permeability at a constant stress  $\mu^T$ , and magnetic-flux density  $B$  within the material.  $B$ ,  $H$ ,  $s^H$  and  $\mu^T$  all have a static bias and a time-varying term  $e^{j\Omega t}$  (for example,  $T(t) = T_0 + T e^{j\Omega t}$ ), which are not to be displayed here. If the magnetostrictive process is assumed to be reversible, then  $d^* = d$ . This would be normally true for low-level driving forces or fields, but for high-level driving they may be different.

Main features on magnetostrictive material Terfenol-D are [10]:

|  |   |
|--|---|
| mechanical compliance                            | $s^H = 3.310^{11} \text{ m}^2/\text{N}$ |
| linear piezomagnetic cross-coupling coefficients | $d = 2.1 \cdot 10^8 \text{ m/A}$        |
| magnetic permeability                            | $\mu^T/\mu^0 = 12$                      |

### The system

Referring to the model reported in Fig.3, two dynamical equation can be written, respectively related to:

mechanics:

$$m\ddot{x} + r\dot{x} = F_{mag} \quad (3)$$

electrics:

$$V = R_0 I + n \frac{d\Phi}{dt} \quad (4)$$

The force exerted by the magnetostrictive actuator :

$$F_{mag} = TA$$

is a function of  $T$  as in eq. (1):

$$T = \frac{-S + dH}{s^H} \quad (5)$$

The applied magnetic-field strength  $H$  is:

$$H = \frac{n}{\delta L} I = \frac{n}{l+x} I \quad (6)$$

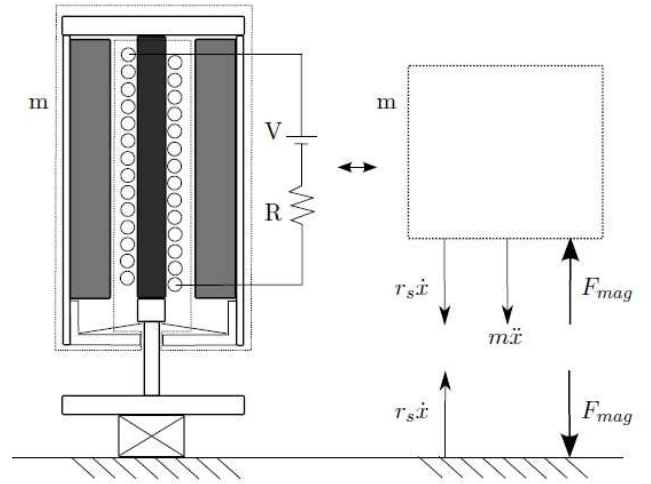

Figure 3 – System model

where  $n$  is the number of the winding turns,  $l$  is the length of the magnetostrictive bar,  $L$  is the length of the bar when  $H=H_0$  and  $T=T_0$ ,  $I$  is the current flowing in the winding and  $\delta$  is a coefficient to take into account the effective length of field lines along which perform the circulation ( $\delta \approx 2$ ).

Then, substituting eq.(6) in eq.(5), one gets:

$$T = -\frac{S}{s^H} + \frac{nd}{s^H} \frac{I}{\delta(l+x)} = -\frac{x/l}{s^H} + \frac{nd}{s^H} \frac{I}{\delta(l+x)} \approx -\frac{x/l}{s^H} + \frac{nd}{s^H} \frac{I}{\delta L} \quad (7)$$

The force exerted by the magnetostrictive actuator is:

$$F_{mag} = TA \approx -k_s x + \frac{ndA}{s^H} \frac{I}{\delta L} \quad (8)$$

where:

$$k_s = \frac{A}{s^H L} \quad (9)$$

is the mechanical stiffness of the magnetostrictive bar.

As reported in Fig.3 force transmitted to the structure, and then the force available to control and suppress vibration is:

$$F_T = F_{mag} - r\dot{x} \quad (10)$$

$$F_T = m\ddot{x} \quad (11)$$

### Transfer functions

Let's suppose to control the device supplying a known current  $I$ . It allows to disregard the electromagnetical dynamic and taking into account just the mechanical behaviour of the system.

Comparing eq. (3), (11) the transfer function between force exerted by the device and the force transmitted to the structure (ground) is:

$$G_1 = \frac{F_T}{F_{mag}} = \frac{m\ddot{x}}{m\ddot{x} + r\dot{x}} \quad (12)$$

and through Laplace's transformation:

$$G_1(s) = \frac{F_T}{F_{mag}} = \frac{s^2}{s^2 + \frac{r}{m}s} \quad (13)$$

Let's derive with respect to time eq.(1) with the condition  $l \approx 1+x$ . Substituting the result in eq.(3) one gets:

$$-ms^H L \ddot{T} + m \frac{dnL}{\delta L} \ddot{I} - rs^H L \dot{T} + r \frac{dnL}{\delta L} \dot{I} = TA \quad (14)$$

And then the transfer function:

$$G_2(s) = \frac{Fmag}{I} = C \frac{s^2 + (r/m)s}{s^2 + (r/m)s + (k/m)} \quad (15)$$

where:

$$C = \frac{ndA}{s^H \delta L} \quad (16)$$

Combining eqs. (14), (16) the transfer function  $G_3(s)$  between the current  $I$  supplied to the actuator and the force  $F_T$  transmitted to the vibrating structure is:

$$G_3(s) = \frac{F_T}{I} = G_1(s)G_2(s) = C \frac{s^2}{s^2 + (r/m)s + (k/m)} \quad (17)$$

### 3. EXPERIMENTAL TESTS

#### Magnetostrictive actuators tested

To validate the model, two different magnetostrictive actuators are tested (Fig.4) whose most significant mechanical features are:

*M.A. E75W*

$A = 9e^{-6}$  [m] Area of a bar section

$L = 64$  [mm] Bar length

$n = 1550$  no. of winding turns

$m = 2$  [kg] inertial mass

$k_s = \frac{A}{s^H L} = 4.26e^6$  [N/m] mechanical stiffness (eq.(9))

*M.A. E30W*

$A = 9e^{-6}$  [m] Area of a bar section

$L = 43$  [mm] Bar length

$n = 1550$  no. of winding turns

$m = 0.74$  [kg] inertial mass

$k_s = \frac{A}{s^H L} = 6.34e^6$  [N/m] mechanical stiffness (eq.(9))



Figure 4 – Magnetostrictive actuators E75W and E30W

Theoretical transfer functions  $G_3(s)$  described in eq.(17) are depicted in Fig.5 for both the magnetostrictive actuators tested.

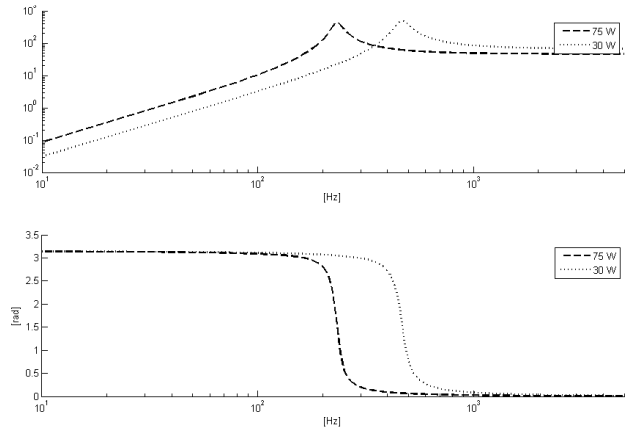

Figure 5 – Theoretical transfer functions of M.A. tested (magnitude and phase)

#### Work bench

The work-bench used for dynamical tests is shown in Fig.6 and Fig.7. The MA are placed on a load cell, fixed to the ground, in order to have their inertial mass free and they are fed with a known current  $I$  that varies over time.

During the tests, signals of voltage ( $V$ ) and supply current ( $I$ ) are acquired, as the acceleration of the base ( $a_b$ ) and the one of the inertial mass ( $a_m$ ) (via uniaxial piezoelectric accelerometers). The force transmitted to the ground ( $F_T$ ) is acquired through a load cell.

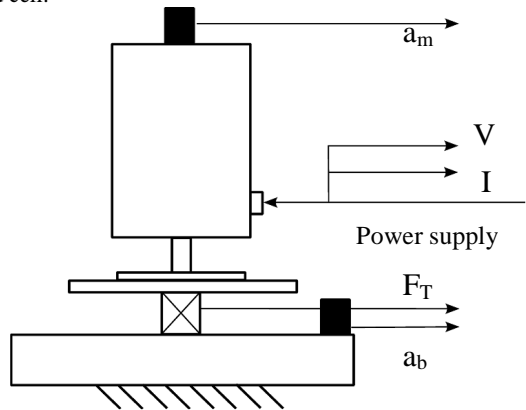

Figure 6 – Measure system layout

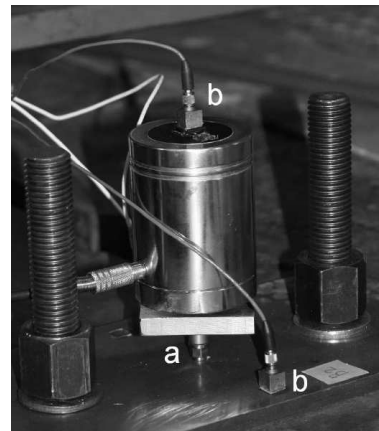

Figure 7 – Test : load cell (a) and unidirectional accelerometers (b)

**Experimental results**

Experimental transfer function  $G_3(s)$  between supplied current and transmitted force are obtained for both the actuators tested. Devices are excited first with an harmonic input current (from 10Hz to 2000Hz), secondly with a sweep sine excitation in the same range of frequencies. tests are repeated for different current gains.

Fig.8 and Fig.9 respectively show the experimental transfer function obtained for the E.30W magnetostrictive actuator, while Fig.10 and Fig.11 are related to the model E.75W.

All the graphs show amplitude and phase of the transfer function and the coherence between the input and the output signal.

Let's remember coherence is defined as:

$$\gamma_{AB}^2 = \frac{|S_{AB}^2(f)|}{S_{AA}(f)S_{BB}(f)} \quad 0 \leq \gamma_{AB}^2 \leq 1$$

where  $S_{AA}(f)$  and  $S_{BB}(f)$  are the auto-spectrums respectively of the input and output signals, while  $S_{AB}(f)$  is their cross-spectrum. The coherence function is a scalar and it assumes a unit value only in case of perfect correlation between the two signals. In other words, it identifies the presence or absence of a “cause-and-effect” relationship between the input signal and output, at different frequencies.

For this reason the experimental transfer function can be acceptable only in the range of frequencies where coherence is near the unit value and has to be neglected elsewhere.

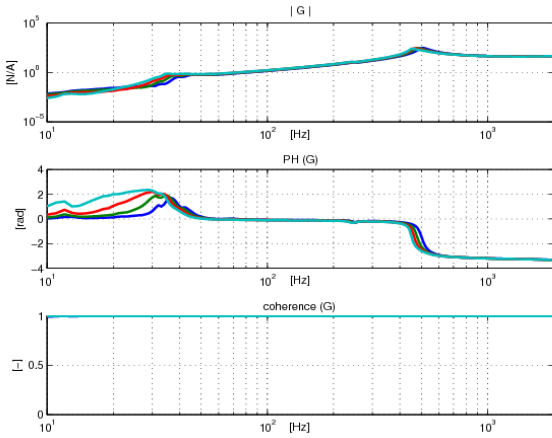

Figure 8 – E.30W MA. Experimental transfer function  $G_3(s)=F_T/I$  obtained with harmonic excitation for different value of current.

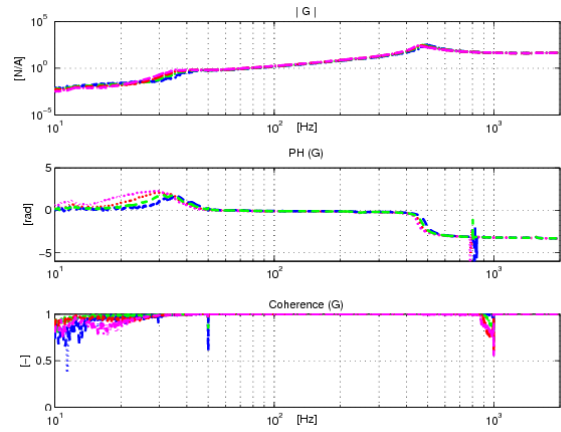

Figure 9 - E.30W MA. Experimental transfer function  $G_3(s)=F_T/I$  obtained with sweep-sine excitation for different value of current.

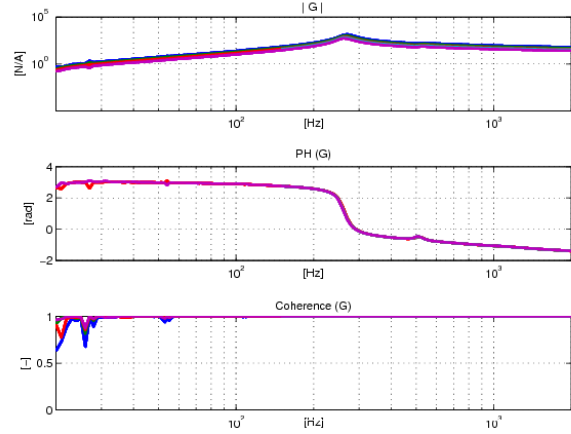

Figure 10 – E.75W MA. Experimental transfer function  $G_3(s)=F_T/I$  obtained with harmonic excitation for different value of current.

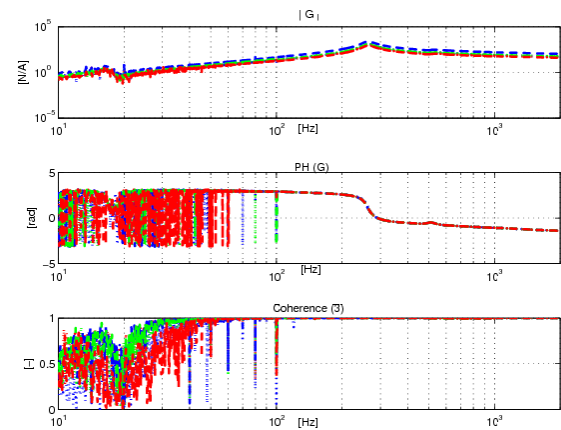

Figure 11 - E.75W MA. Experimental transfer function  $G_3(s)=F_T/I$  obtained with sweep-sine excitation for different value of current.

The experimental transfer functions are well defined for frequency higher than 40 Hz, where the force exerted by the actuator is so small that the transducer can't appreciate it. This effect is evident looking the coherence between the input and output acquired signals reported in graphs. Tests with harmonic excitation allow to reach a better result, especially in low frequencies operating field.

#### 4. THEORETICAL AND EXPERIMENTAL COMPARISON

The comparison between the theoretical transfer function and the experimental ones are shown in figures 12-15.

For each actuator tested, both the functions uniquely identify the resonant frequency of the system and properly describe its dynamical behaviour in the range of frequency of interest. A small shift-effect in experimental transfer functions is associated to current gain. This effect can't be evaluated in the model but it is really negligible.

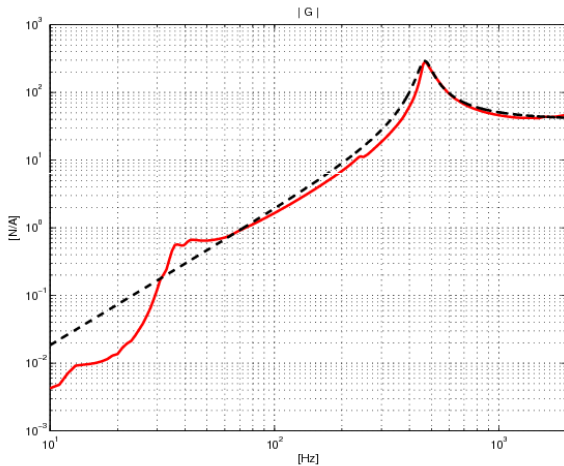

Figure 12 – E.30W Magnetostrictive actuator: comparison between experimental and theoretical transfer function  $G_3=F_T/I$  (Amplitude)

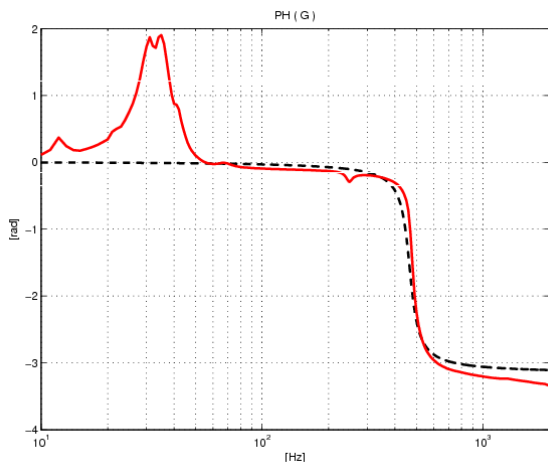

Figure 13 – E.30W Magnetostrictive actuator: comparison between experimental and theoretical transfer function  $G_3=F_T/I$  (Phase)

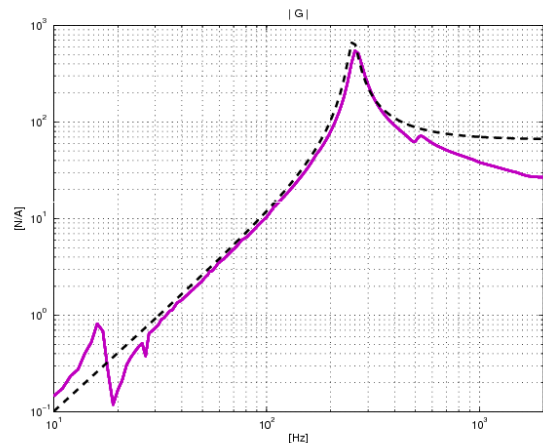

Figure 14 – E.75W Magnetostrictive actuator: comparison between experimental and theoretical transfer function  $G_3=F_T/I$  (Amplitude)

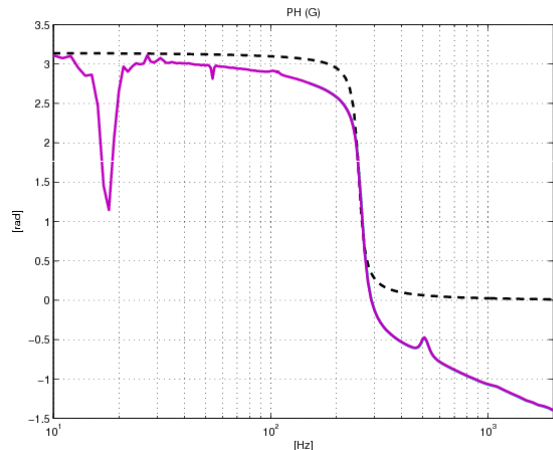

Figure 15 – E.75W Magnetostrictive actuator: comparison between experimental and theoretical transfer function  $G_3=F_T/I$  (Phase)

#### 5. CONCLUSIONS

Magnetostrictive actuators are a promising technology in active vibrations control field. The paper investigates the opportunity of modelize such devices with a linear model to correctly describe their mechanical behaviour. A transfer function between the supplied current and the force usefull to controll a vibrating system has been introduced. The model has been validated testing two different actuators in a range of frequencies between 10-2000Hz. The comparison between theoretical transfer function and experimental ones confirm the goodness of the proposed model.

#### REFERENCES

- [1] G. Engdahl, "Handbook of Giant Magnetostrictive Materials", Academic press, 2000
- [2] J.L. Pons, "Emerging Actuator Technologies: A Micromechatronic Approach", John Wiley & Sons Ltd, 2005

- [3] S.J. Moon, C.W. Lim, B.H. Kim, Y Park, "Structural Vibration Control Using Linear Magnetostrictive actuators", **Journal of Sound and Vibration**, Vol.302, 2007, pp.875-891.
- [4] J.S. Kumar, N. Ganesan, S. Swarnamani, C. Padmanabhan, "Active Control of Cylindrical Shell with Magnetostrictive Layer", **Journal of Sound and Vibration**, Vol.262, 2003, pp.577-589.
- [5] T. Zhang, C. Jang, H. Zhang, H. Xu, "Giant Magnetostrictive Actuators for Active Vibration Control", **Smart Material and Structures**, Vol.13, 2004, pp.473-477.
- [6] P.A. Bartlett, S.J. Eaton, J. Gore, W.J. Metheringham, A.G. Jenner, "High-power, low frequency magnetostrictive actuation for anti-vibration application", **Sensors and Actuators A**, Vol.91, 2001, pp.133-136
- [7] C. Li, J. Mao, "Active Vibration Control under the actuator with magnetic Hysteresis Loop", **Proceedings of 2005 International Conference on Control and Automation ICCA2005**, Budapest, Hungary
- [8] C. May, K. Kuhnen, P. Pagliaruolo, H. Janocha, "Magnetostrictive Dynamic Vibration Absorber (DVA) for Passive and Active Damping", **Proceedings of Euronoise 2003**, Naples, Italy
- [9] T.S. Koko, U.O. Akpan, A. Berry, P. Masson, O. Besslin, J. Szabo, N. Sponagle, "Vibration control in ship structures", **Encyclopedia of Smart Materials**, Voll.1,2, John Wiley & Sons Ltd, 2002
- [10] A.E. Clark, H.T. Savage, M.L. Spano, "Effect of Stress on Magnetostriction and Magnetization of Single Crystal of  $Tb_{27}Dy_{73}Fe_2$ ", **IEEE Transactions on magnetics**, Vol. MAG-20, No.5, 1984, pp.1443-1445.
- [11] M.J. Dapino R.C. Smith, L.E. Faidley, A.B. Flatau, "A Coupled Structural-Magnetic Strain and Stress Model for Magnetostrictive Transducers", **Journal of Intelligent Material Systems and Structures**, Vol.11, 2000, pp.135-151.
- [12] X. Zhao, D.G. Lord, "Application of the Villari effect to electric power harvesting", **Journal of Applied physics**, Vol.99, 2006, pp.135-151.
- [13] M.J. Dapino, "Magnetostrictive Materials", **Encyclopedia of Smart Materials**, Voll.1,2, John Wiley & Sons Ltd, 2002
- [14] O. Thomas, S. Mahon, S. C. Busbridge, and A. R. Piercy, "Variation of the Magnetoelastic Properties of Terfenol-D with Sample Thickness", **IEEE Transactions on magnetics**, Vol.37, No.4, 2001, pp.2687-2689.